



150, 300, 400 MW Second Generation CAES Plant Concepts Based on Various Combustion Turbines

“PLC and ES&P” developed a number of novel CAES concepts (“Second Generation CAES”), that are highly scalable and provide power generators with a number of practical and cost-effective choices. Second Generation CAES provides a high degree of flexibility to meet a variety of specific operational, economical and load conditions to enhance wind and other renewable energy generation. These concepts are based on various combinations of the major standard components, including existing or new combustion turbines, air compressors, air expanders and heat recovery recuperators, all integrated with compressed air energy storage and power augmentation, and optimized for the specific operational, economic and geological conditions of the site.

Contact:

Power Lines Communication Co.

info@powerlinesco.com

www.powerlinesco.com

Othman Ali Hazza

Chief Executive Officer

othman@powerlinesco.com

Azhar Iqbal

Manager Operations

azhar@powerlinesco.com

PLC and ES&P's Unique Experience in the CAES Technology

Engineering, Construction, Tests and Operations of the 110 MW CAES Projects

The Compressed Air Energy Storage (CAES) technology is the only technology that is capable of providing energy management in the range of thousands of MWh- i.e. the energy storage during off-peak hours and energy generation during peak hours when the energy is needed and the price is higher.

The simplified schematic (below) illustrates a CAES unit Major features:

During off-peak hour's motor-driven compressors (blue component on the left) utilize the wind or an any other renewable energy and store it in the form of compressed air in underground reservoir. During peak hours the stored air is extracted from the storage, preheated and generates peak power by air expanders (red component on the right).

Simplified Schematic of CAES Plant

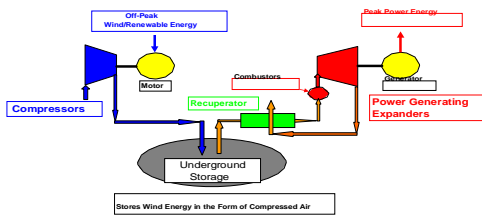

The significant interest in the CAES units is driven primarily by very extensive developments of the wind and other renewable resource projects and by the current emphasis on the coal/nuclear power plants (associated with high current natural gas fuel costs) – all requiring significant load management.

ES&P is the only company that was involved in all stages of execution of the 110 MW CAES project- the only CAES project in the US - including the feasibility study, detail engineering, construction, performance tests and first three years of operation.

Electric Power Research Institute is very active in promoting of the CAES technology and co-sponsored the 110 MW CAES project for Alabama Electric Cooperative.

Alabama Compressed Air Energy Storage Plant
 Peak Power 110 MW; 26 hrs of continuous Power Generation;
 Heat rate is 4000 Btu/kWh; Off-Peak Power 51MW



Schematic for AEC CAES Plant (110 MW – 26 Hour)

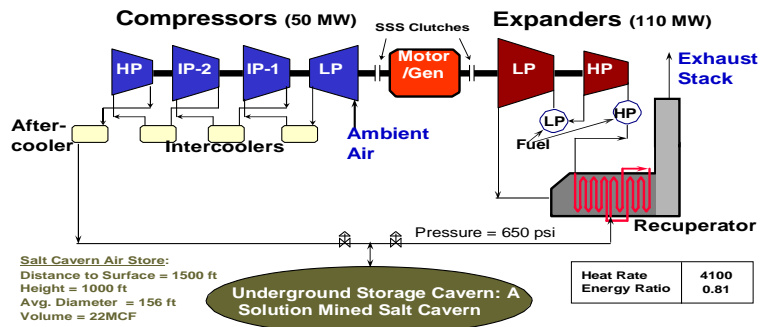

ES&P has seven patents on the CAES technology- some of them were applied for the AEC CAES project .

Below is the ES&P team receiving EPRI's Award for Outstanding Performance in the execution of the 110 MW CAES project.

150 MW CAES Unit

PLC and ES&P offers a number of second generation CAES plant concepts with approximately 150 MW of net generation output; flexible to be optimized based on specific economic, operational and ambient temperature conditions. The concepts presented below are based on power augmented GE 7B combustion turbine integrated with the Bottoming Cycle and specifically well suited for high ambient temperature regions. The unit uses approximately 60% less fuel than an open cycle combustion turbine and 40% less fuel than a combined cycle unit. The 150 MW CAES plant concepts could be based on variety of CTs- new or used.

CAES with Bottoming Cycle and Air Injection*

The patented Second Generation CAES with Bottoming Cycle and Air Injection employs a GE 7211B combustion turbine, producing approximately 170 MW of net power, and has a fuel related heat rate of 3,800-4,000 Btu/kWh (LHV).

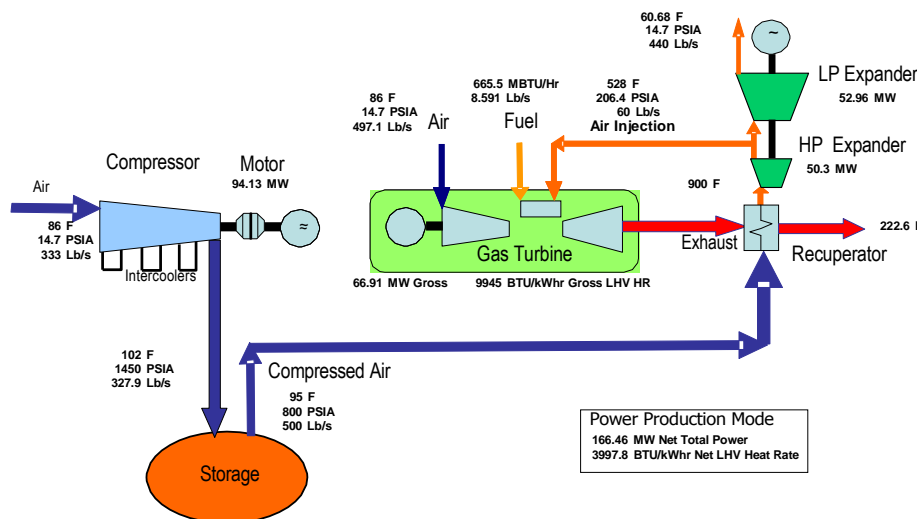

CAES with Bottoming Cycle and Inlet Chilling*

The patented Second Generation CAES with Bottoming Cycle and Inlet Chilling employs a GE 7211B combustion turbine, producing approximately 175 MW of power, and has a fuel related heat rate of 3,800-4,000 Btu/kWh (LHV).

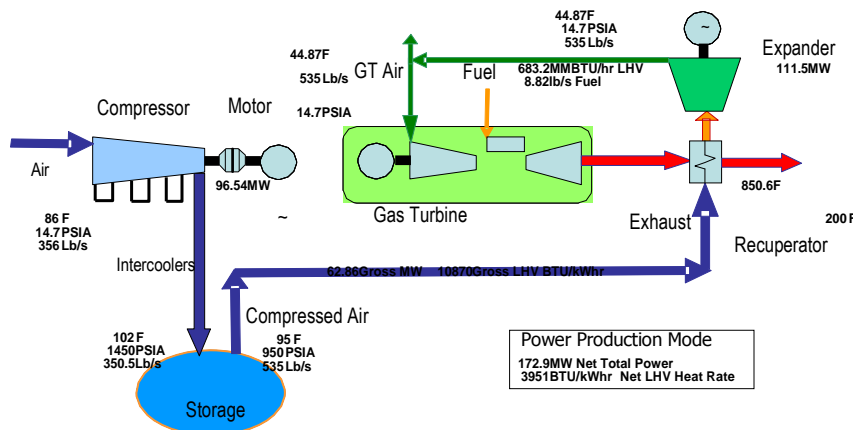

* The diagrams require ~1.5 hours of compression for every hour of generation



300 MW CAES Unit

PLC and ES&P offers a number of second generation CAES plant concepts with approximately 300 MW of net generation output; flexible to be optimized based on specific economic, operational and ambient temperature conditions. The concepts presented below are based on power augmented on GE9171E combustion turbine integrated with the Bottoming Cycle and specifically well suited for high ambient temperature regions. The unit uses approximately 60% less fuel than an open cycle combustion turbine and 40% less fuel than a combined cycle unit. The 300 MW CAES plant concepts could be based on variety of CTs- new or used.

CAES with Bottoming Cycle and Air Injection*

The patented Second Generation CAES with Bottoming Cycle and Air Injection employs a GE 9171E combustion turbine, producing approximately 333 MW of net power, and has a fuel related heat rate of 3,800-4,000 Btu/kWh (LHV).

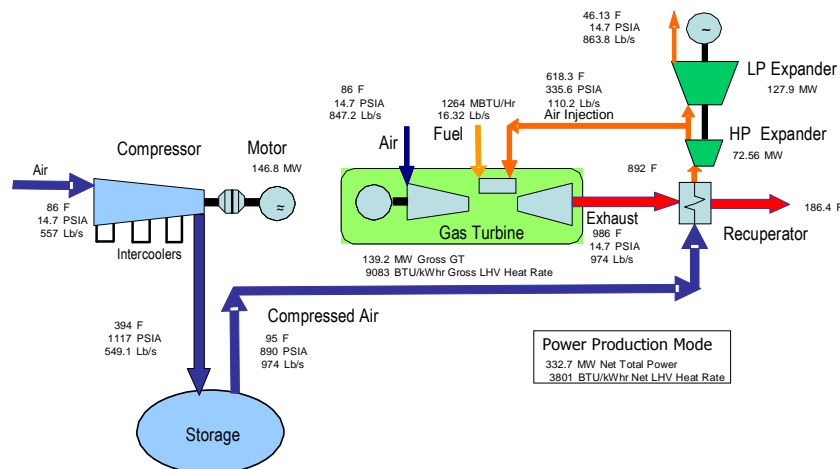

CAES with Bottoming Cycle and Inlet Chilling*

The patented Second Generation CAES with Bottoming Cycle and Inlet Chilling employs a GE 9171E combustion turbine, producing approximately 327 MW of power, and has a fuel related heat rate of 3,800-4,000 Btu/kWh (LHV).

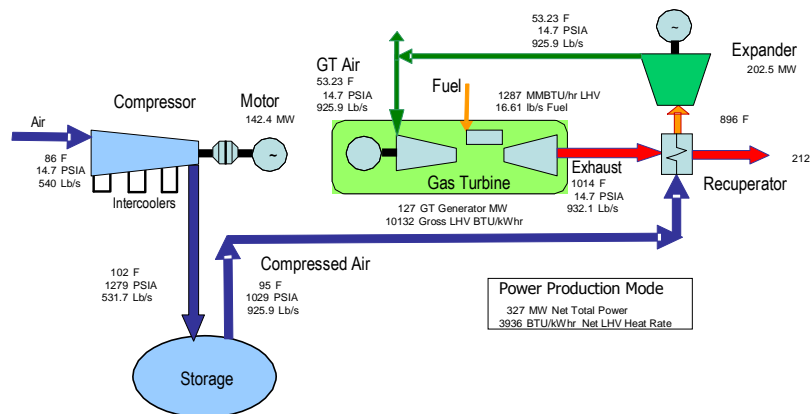

* The diagrams require ~1.75 hours of compression for every hour of generation



400 MW CAES Unit

PLC and ES&P offers a number of second generation CAES unit concepts with approximately 400 MW of net generation output; flexible to be optimized based on specific economic, operational and ambient temperature conditions. The presented below concepts are based on power augmented on GE 7241FA combustion turbine integrated with the Bottoming Cycle and specifically well suited for high ambient temperature regions. The unit uses approximately 60% less fuel than an open cycle combustion turbine and 40% less fuel than a combined cycle unit. The 400 MW CAES plant concepts could be based on variety of CTs- new or used.

CAES with Bottoming Cycle and Air Injection*

The patented Second Generation CAES with Bottoming Cycle and Air Injection employs a GE 7241FA combustion turbine, producing approximately 433 MW of net power, and has a fuel related heat rate of 3,800-4,000 Btu/kWh (LHV).

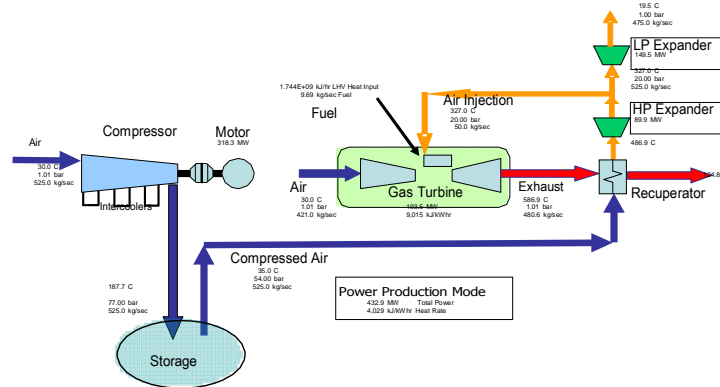

CAES with Bottoming Cycle and Inlet Chilling*

The patented Second Generation CAES with Bottoming Cycle and Inlet Chilling employs a GE 7241FA combustion turbine, producing approximately 427 MW of power, and has a fuel related heat rate of 3,800-4,000 Btu/kWh (LHV).

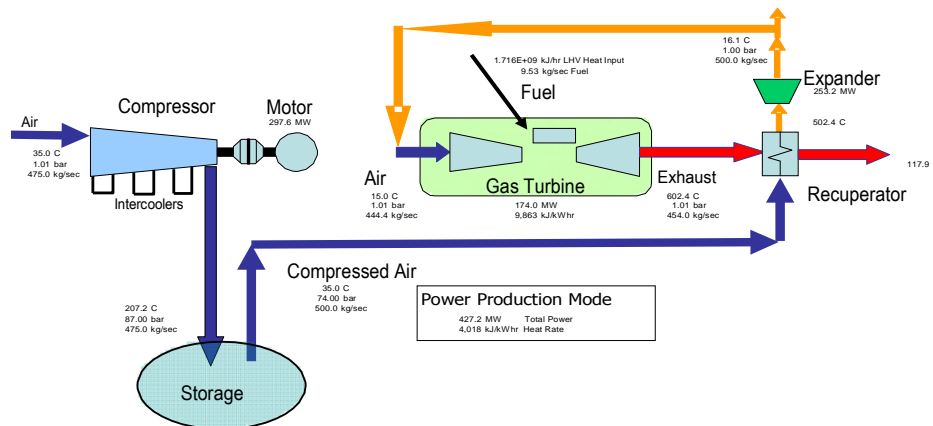

* The diagrams require ~1 hour of compression for every hour of generation



PLC and ES&P is capable of delivering CAES projects on an EPC basis.

A study budget generic estimate for the capital cost of an underground storage CAES project, is approximately \$750/kW (2008). Expected delivery time is approximately 30-36 months, primarily driven by site permitting and equipment delivery.

These concepts are based on various combinations of the major standard industry components – existing or new combustion turbines, air compressors, air expanders and a heat recovery recuperator – all integrated with a compressed air reservoir and engineered for specific operational, economic and geological conditions.

Customers have a choice of a selection of combustion turbines based on their preferences, PLC and ES&P will design/engineer the CAES units based on the selected combustion turbine. These illustrative heat & mass balances are based on GE 7B, GE 9E and GE 7FA CTs for 150 MW, 300 MW and 400 MW CAES units respectively.

Other suppliers of typical components include but not limited to:

Air Compressors: MAN Turbo, Dresser-Rand, Mitsubishi and Ingersoll-Rand

Turbo-Expanders: MAN Turbo, Skoda, Atlas Copco, Mitsubishi and Hitachi

Recuperator: RGP Engineering, Nooter/Eriksen, Deltech, and BHEL

The Second Generation CAES unit concept moves CAES technology towards lower capital costs, shorter delivery times, and greater operational flexibility.

EPRI validated novel ES&P concepts and jointly with ES&P presented them to a number of utilities and power generation companies in the US. ES&P is involved in development work for a number of clients worldwide.

Contact:

Power Lines Communication Co.

Info@powerlinesco.com

www.powerlinesco.com

Othman Ali Hazza

Chief Executive Officer

othman@powerlinesco.com

Azhar Iqbal

Manager Operations

azhar@powerlinesco.com

